



# STANDARD PRODUCTS

SONOMA CAST STONE CORPORATION  
 Makers of NuCrete™, The World's Only Stainless Concrete  
 877.283.1897 • www.sonomastone.com



For more product info, or to download replacement forms, see: [www.sonomastone.com](http://www.sonomastone.com)

## Vessel Stand (Metal) & Counter VS-STND-BR

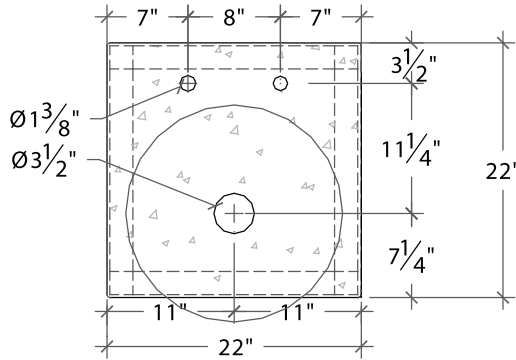

PLAN

Faucet holes cast to customer specifications.

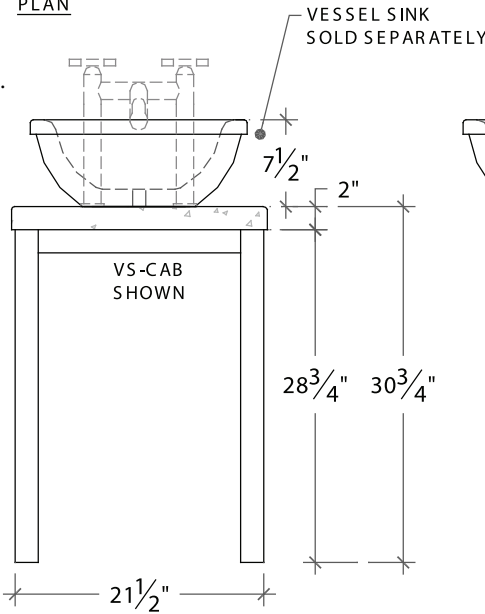

FRONT ELEVATION

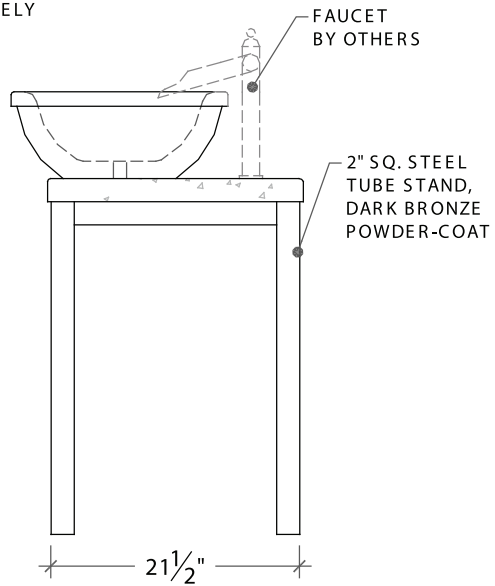

SIDE ELEVATION

Designs ©2007 Sonoma Cast Stone Corp. All rights reserved.

Visit [www.sonomastone.com](http://www.sonomastone.com) to see photos of this and other products.

### • DESCRIPTION

Our simple Vessel Stand features a hefty concrete countertop which rests on Steel legs attached by a 2" Steel apron on all sides. The stands are stocked in powder-coated bronze finish. This unit accommodates any of our concrete VesselSinks™.

Faucet holes are pre-cast to accommodate a 2-hole faucet. A 3 1/2" diameter drain hole allows for some flexibility in bowl placement. Additional colors and hole options are available.

The WaterBridge faucet from Sonoma Forge is designed to compliment VesselSinks™.

### • FACTS

Metal stand of 2" square tube steel comes standard in powder coated dark bronze finish. Countertop comes standard in Classic Concrete, diamond sanded, sealed and waxed. Non-stock Stainless NuCrete™ also available.

Available in any of our standard 24 colors. Custom colors also available. Finish options Classic Concrete or Stain free NuCrete™. See: [www.sonomastone.com](http://www.sonomastone.com), catalog or techbinder. Custom colors available. Order samples online, or call 877-283-2400 x113.

VesselSinks™ sold separately.

Approximate Weight: 108 lbs / Crated 214 lbs.