

CAPACITY: 85 GALLONS (3" FROM RIM)  
 APPROXIMATE DRY WEIGHT: 800LB.  
 FILLED WEIGHT 1,480LB

PLAN

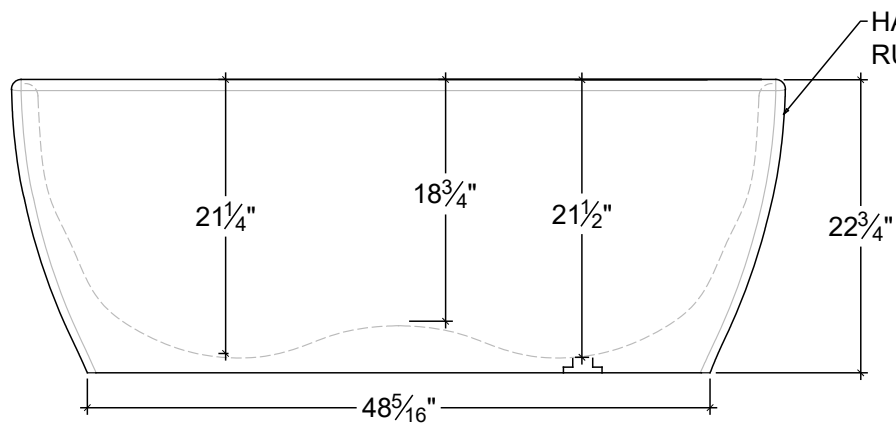

FRONT ELEVATION

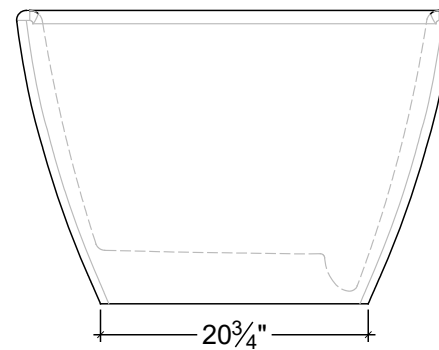

SIDE ELEVATION

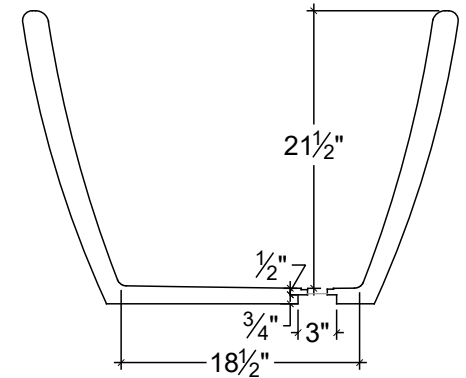

SECTION @ DRAIN