



TILES & PAVERS

SONOMA CAST STONE CORPORATION
 Makers of NuCrete™, The World's Only Stainless Concrete
 877.283.1897 • www.sonomastone.com

For more product info, or to download replacement forms, see: www.sonomastone.com

Tile • Accessories

BARLINER / CAP

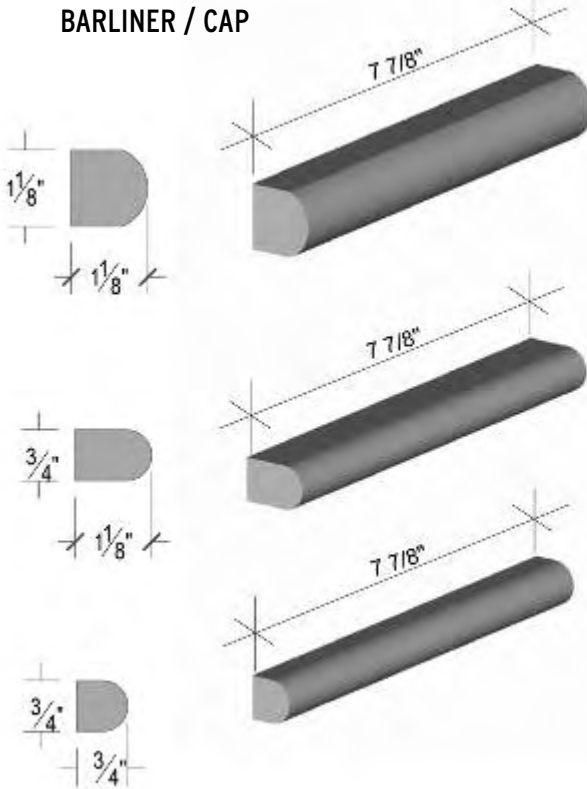

SURFACE BULLNOSE

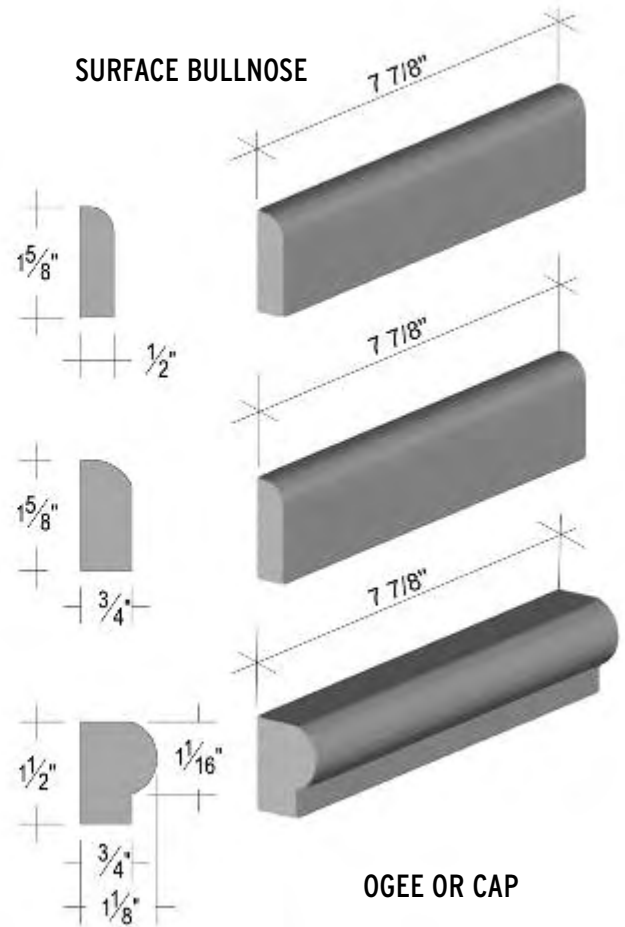

OGEE OR CAP

Designs ©2007 Sonoma Cast Stone Corp. All rights reserved.

Visit www.sonomastone.com to see photos of this and other products.

• DESCRIPTION

Pre-cast concrete accessory tiles in various profiles to use with our other tiles to create a finished look.

Accessory pieces are finished on all exposed sides.

• FACTS

- In Classic Concrete, mold-release finish.
- 24 standard colors. See: www.sonomastone.com, catalog or techbinder.
- Custom colors available. Order samples online, or call 877-283-2400 x113.
- Tiles are "as is" when released from their molds.
- Tiles are not diamond-sanded, sealed and waxed. (Optional)
- Tiles are currently not available Stainless NuCrete™.
- Tiles are unfinished and unsealed. Sealing by installer.
- Thin-set mortar can be used to level substrate.