



STANDARD PRODUCTS

SONOMA CAST STONE CORPORATION
 Makers of NuCrete™, The World's Only Stainless Concrete
 877.283.2400 • www.sonomastone.com



For more product info, or to download replacement forms, see: www.sonomastone.com

CounterTile™ Traditional Cabinet KC-TRA

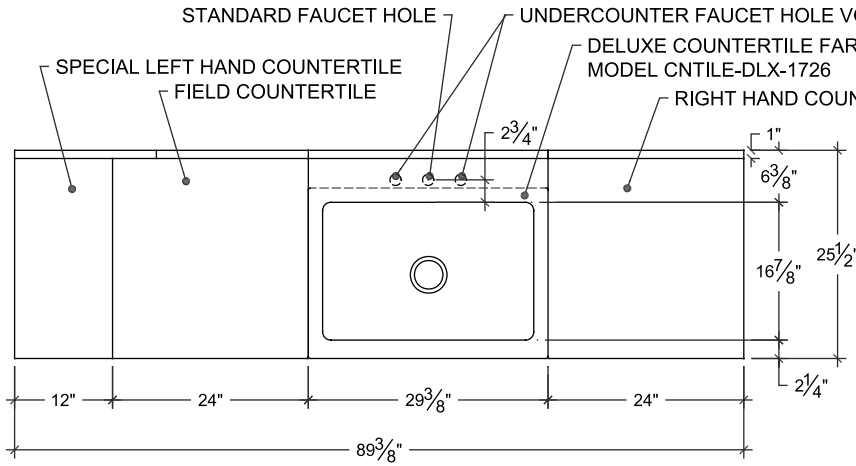

PLAN

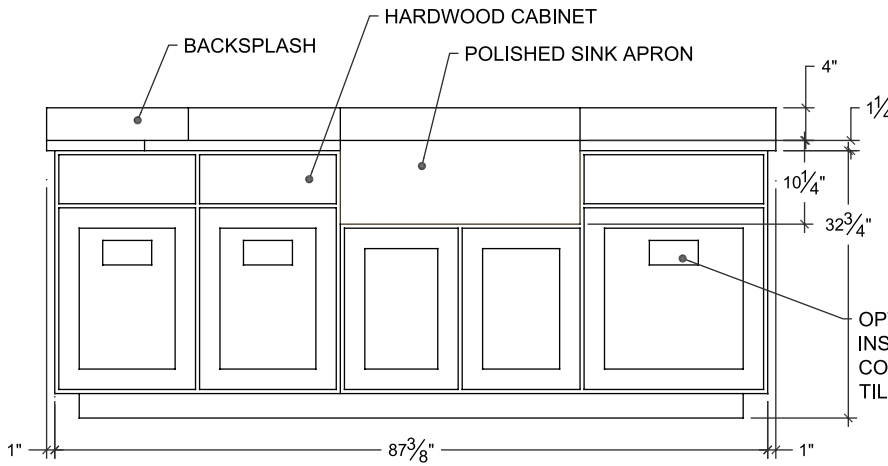

FRONT ELEVATION

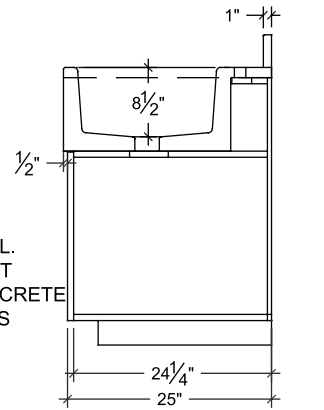

SECTION THROUGH SINK

Designs ©2007 Sonoma Cast Stone Corp. All rights reserved.

Visit www.sonomastone.com to see photos of this and other products.

• DESCRIPTION

Traditional style hardwood kitchen cabinet in stained finish for use with CounterTile™ system of tiles and a choice of a FarmSink in Stainless NuCrete™ (shown in drawing) or stainless steel sinks.

See separate FactSheets for each sink option.

• FACTS

Cabinets constructed in hardwood with stained finish. Handles/knobs not included.

For use with CounterTile™ countertop and matching CounterTile™ FarmSinks in Stainless NuCrete™ or stainless steel.

Approximate Weight: 510 LBS / Crated: 825 lbs (Cabinet only)