

# LANDSCAPING PRODUCTS

SONOMA CAST STONE CORPORATION  
Makers of NuCrete™, The World's Only Stainless Concrete  
877.283.1897 • www.sonomastone.com

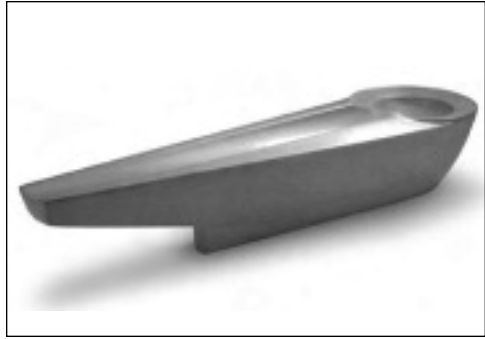

For more product info, or to download replacement forms, see: [www.sonomastone.com](http://www.sonomastone.com)

Enki

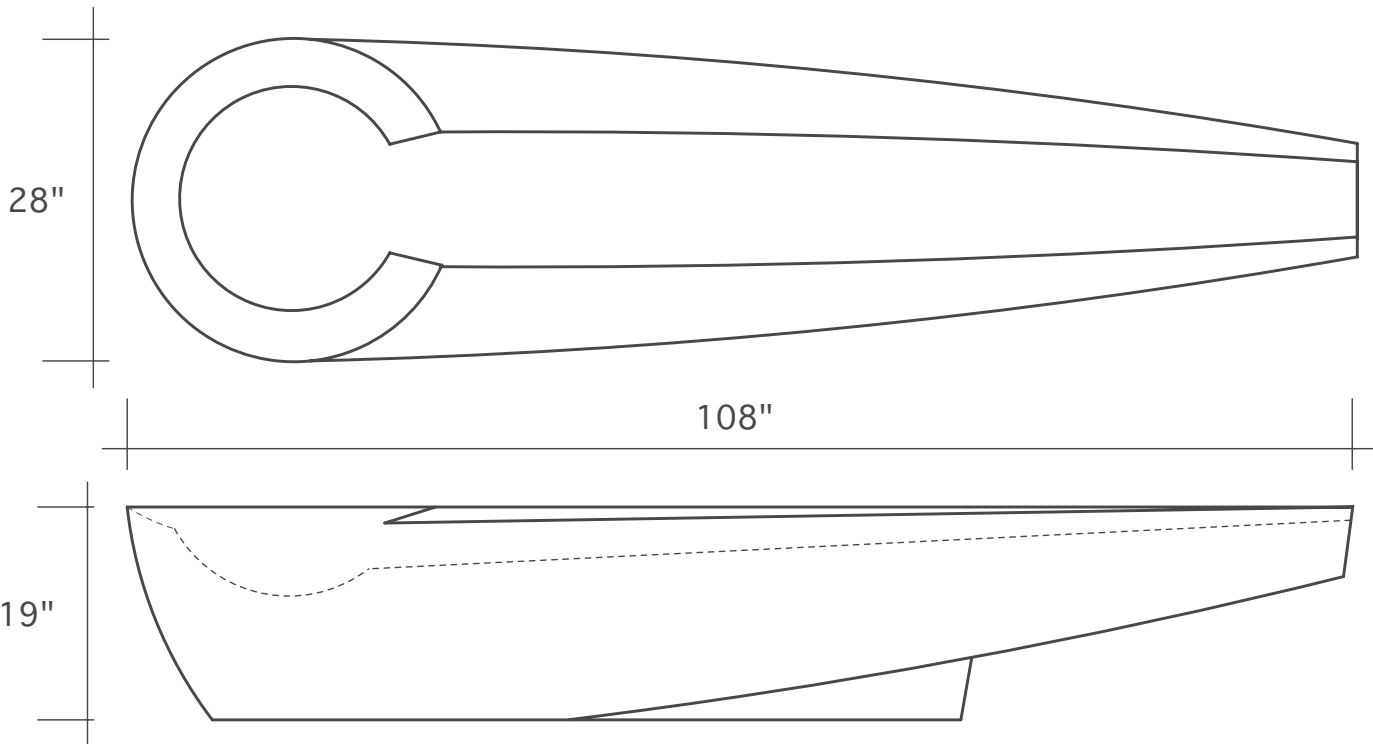

Visit [www.sonomastone.com](http://www.sonomastone.com) to see photos of this and other products.

## • DESCRIPTION

The Enki takes its original inspiration from an earlier Charles Swanson project design—a commissioned rain catcher. With a one hundred and eight inch footprint, the long, sleek lines of this sculptural form flow gradually down into a generous and meticulously sculpted bowl.

As a planter Enki's flume-like body and/or sculpted bowl converts "rain catcher" into the "penthouse" of garden planters. As a fountain this award-winning form becomes a stunning way to feature the movement of water within a garden or architectural interior. Enki as a basin allows you to feature a larger body of water within an interior space.

## • FACTS

Height: 20"  
Length: 96"  
Width: 17"  
Depth: 7.75"